

Service Schematics

NOKIA N82

RM-313/RM-314

Introduction

IMPORTANT:

This document is intended for use by authorized NOKIA service centers only.

“Service Schematics” was created with focus on customer care. The purpose of this document is to provide further technical repair information for NOKIA mobile phones on Level 3/4 service activities. It contains additional information such as e.g. “Component finder”. The “Signal overview” page gives a good and fast overview about the most important signals and voltages on board. Saving process time and improving the repair quality is the aim of this document. It is to be used additionally to the service manual and other training or service information such as Service Bulletins.

All measurements were made using following equipment:

Nokia repair SW : Phoenix version 2007.20.9.28808
Oscilloscope : Fluke PM 3380A/B
Spectrum Analyzer : Advantest R3162 with an analog probe
RF-Generator / GSM Tester : Rhode & Schwarz CMU 200
Multimeter : Fluke 73 Series II

While every endeavour has been made to ensure the accuracy of this document, some errors may exist. If the reader finds any errors, NOKIA shall be notified in writing.

Please send E-Mail to: TrainingAndVendor.Development@nokia.com

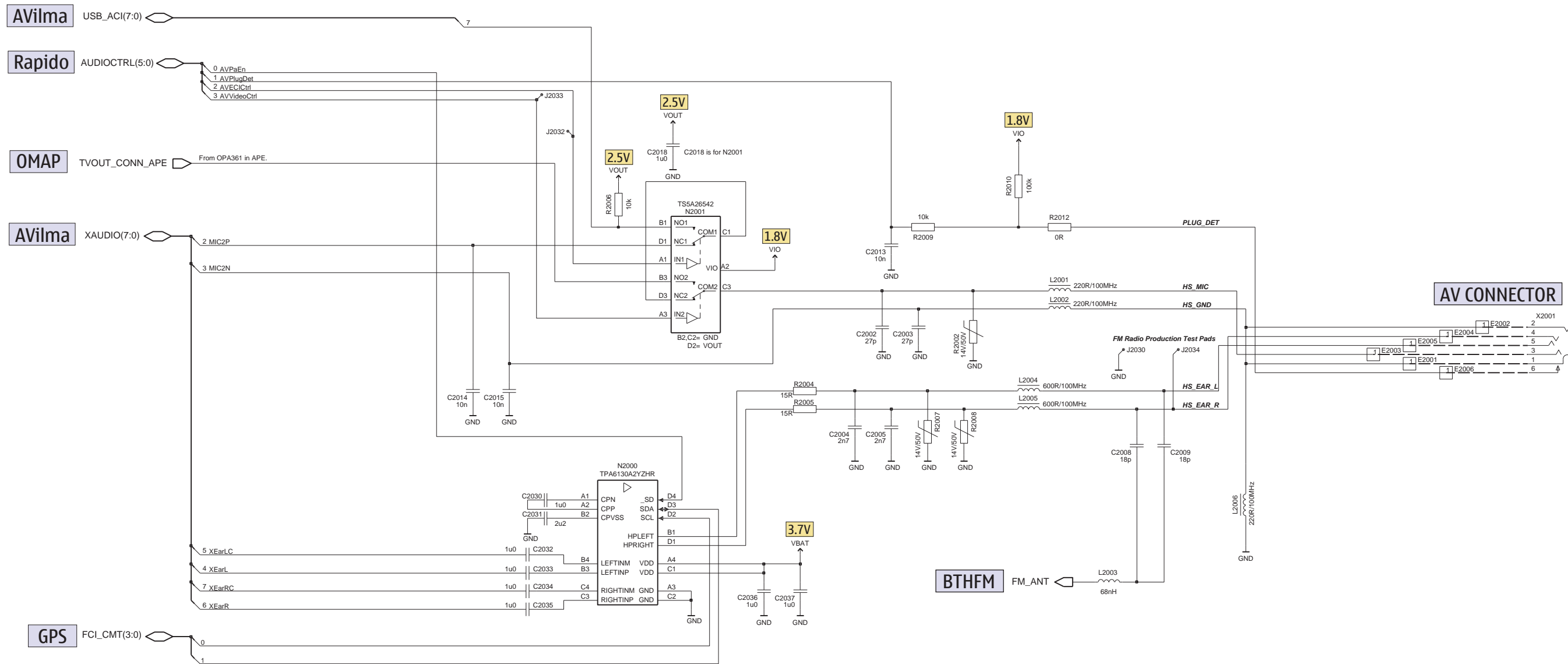

Table of Content

Front page	1
AV connector	2
AVilma, Betty	3
Rapido, Memories, GPS	4
Menelaus, microSD	5
OMAP	6
Camera, HWA	7
WLAN, Bluetooth	8
Display, Backlight, UI connector	9
UI PWB	10
RF part RM-313	11
RF part RM-314	12
Signal overview	13
Component finder RM-313	14
Component finder RM-314	15

Copyright © NOKIA

This material, including documentation and any related computer programs is protected by copyright, controlled by NOKIA. All rights are reserved. Copying, including reproducing, modifying, storing, adapting or translating any or all of this material requires the prior written consent of NOKIA. This material also contains company confidential information, which may not be disclosed to others without the prior written consent of NOKIA.



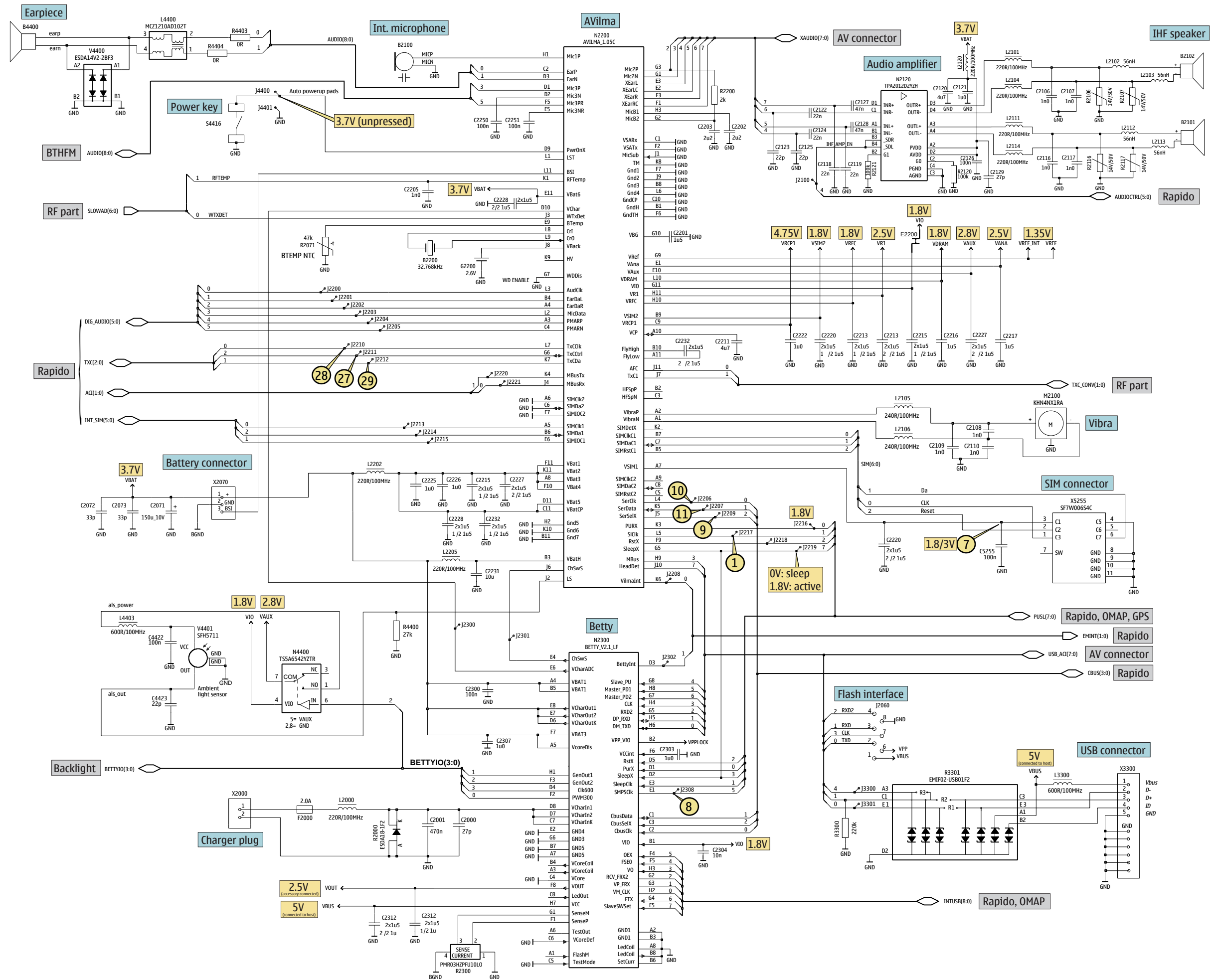

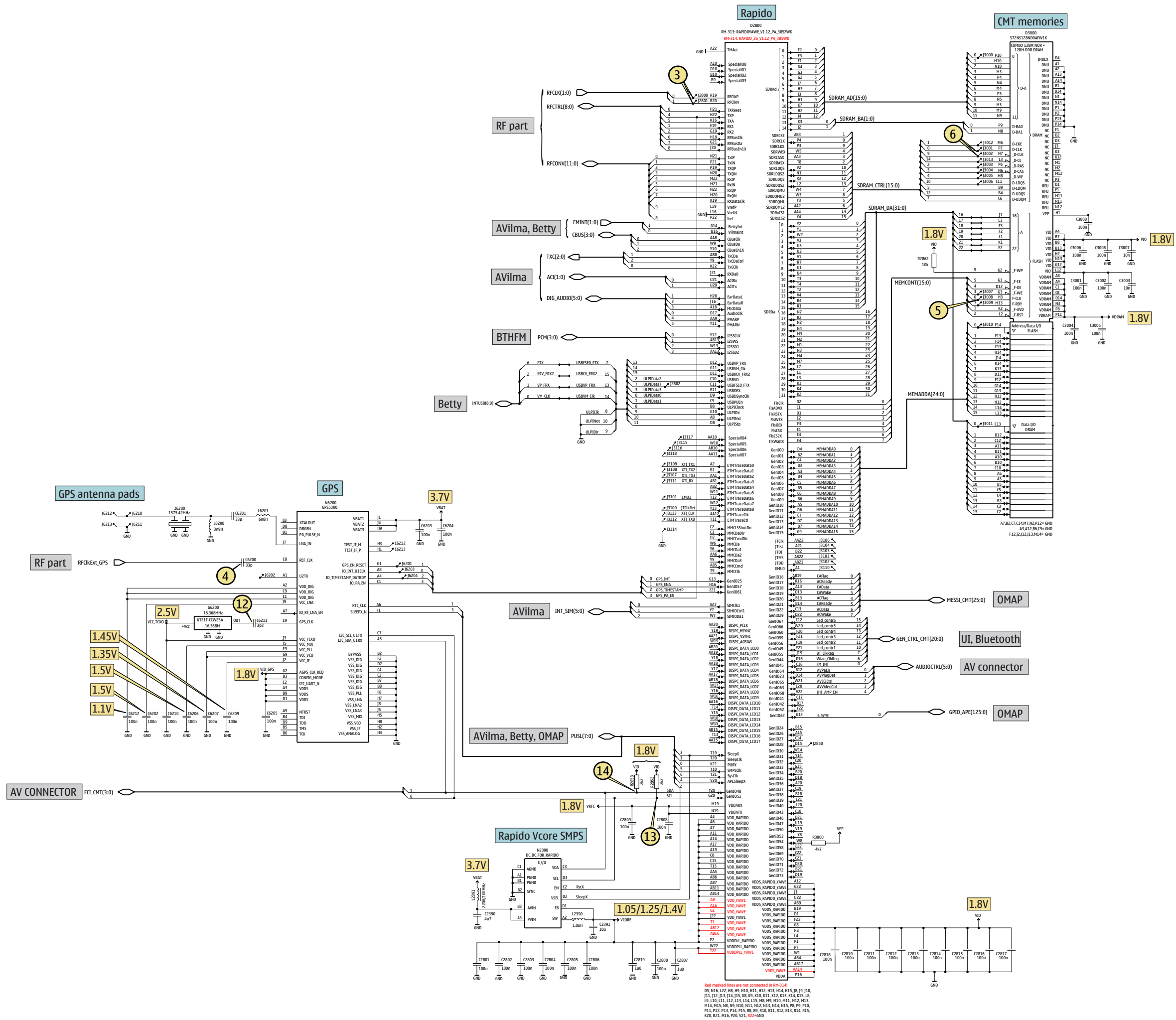

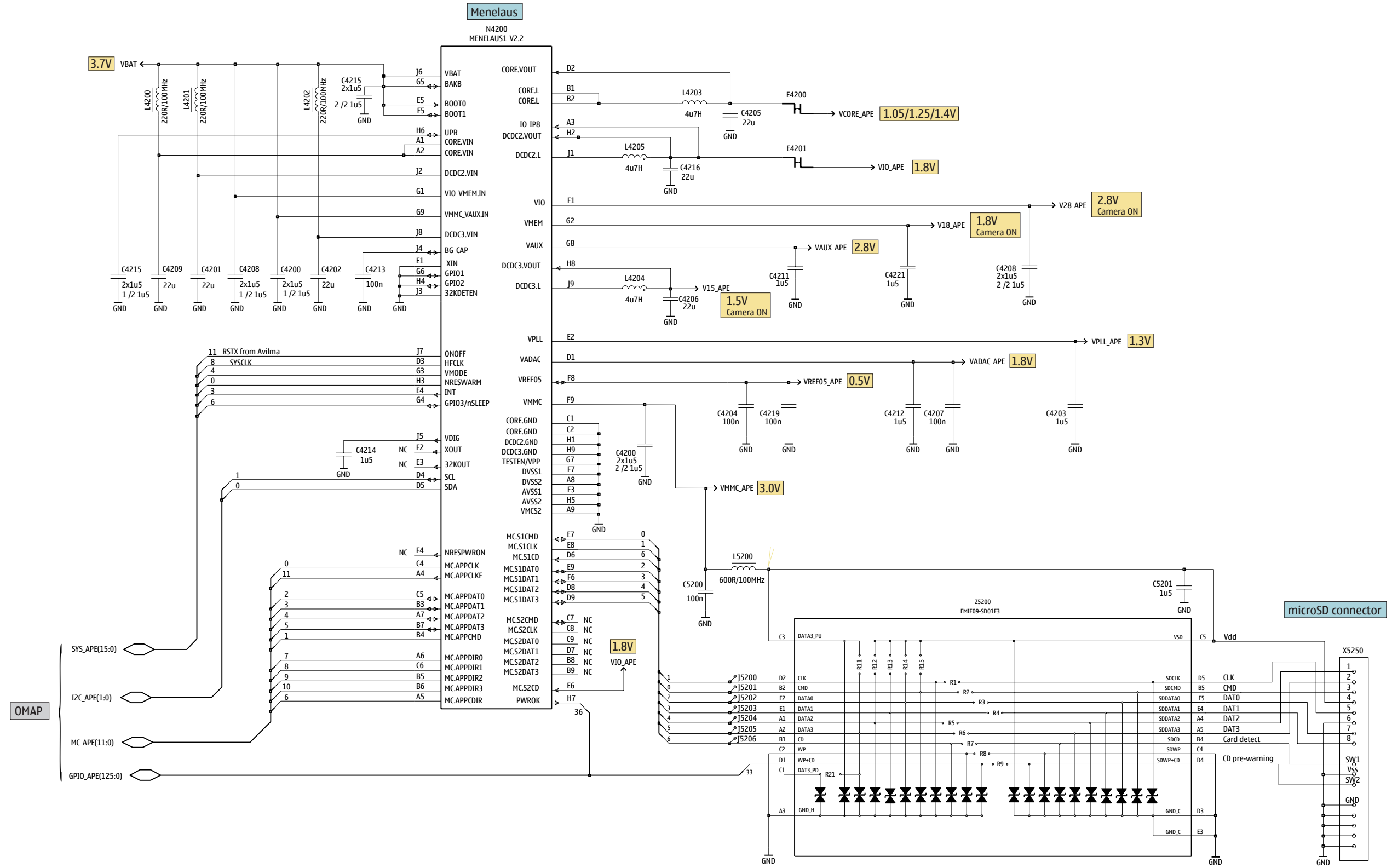

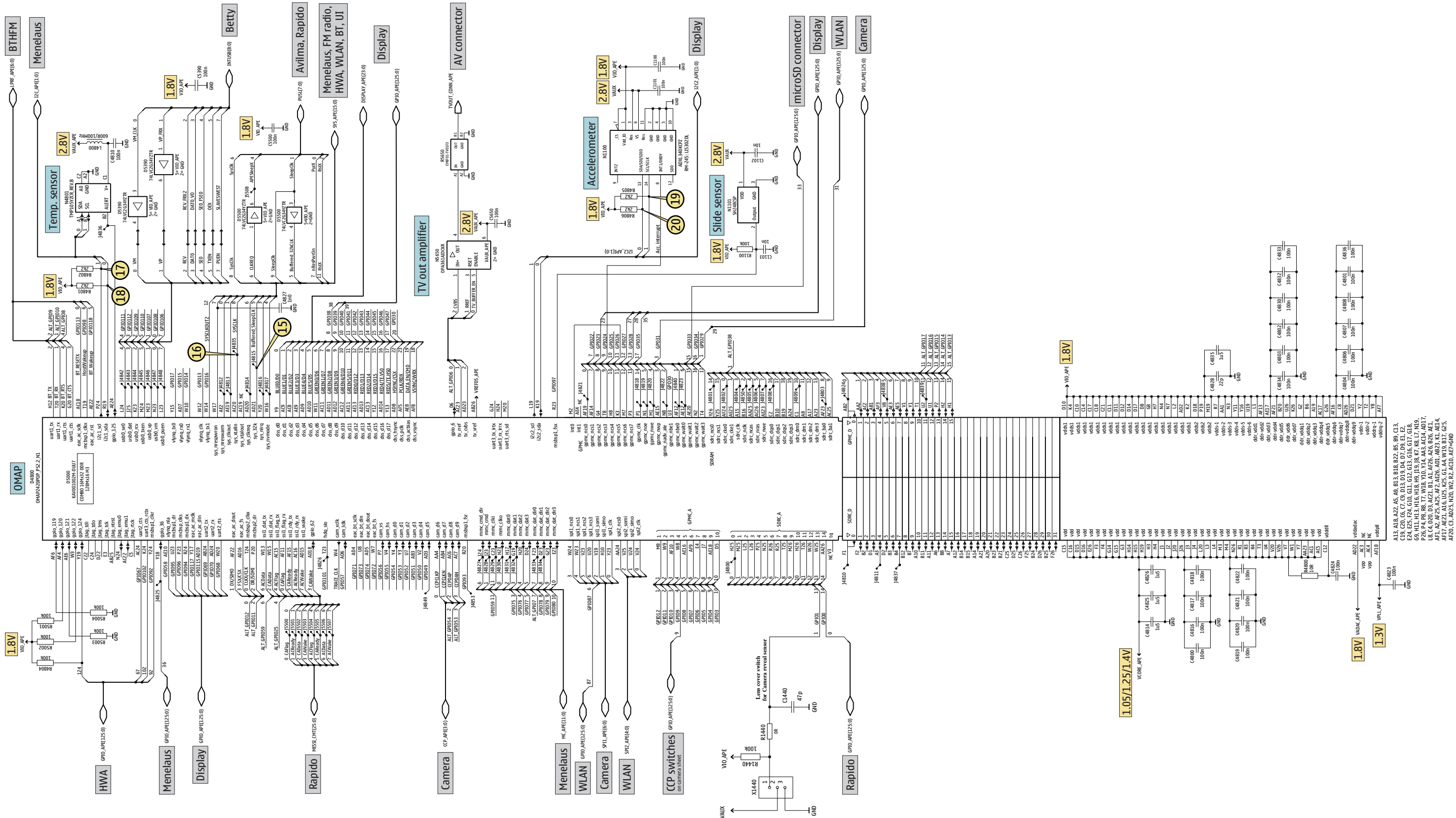

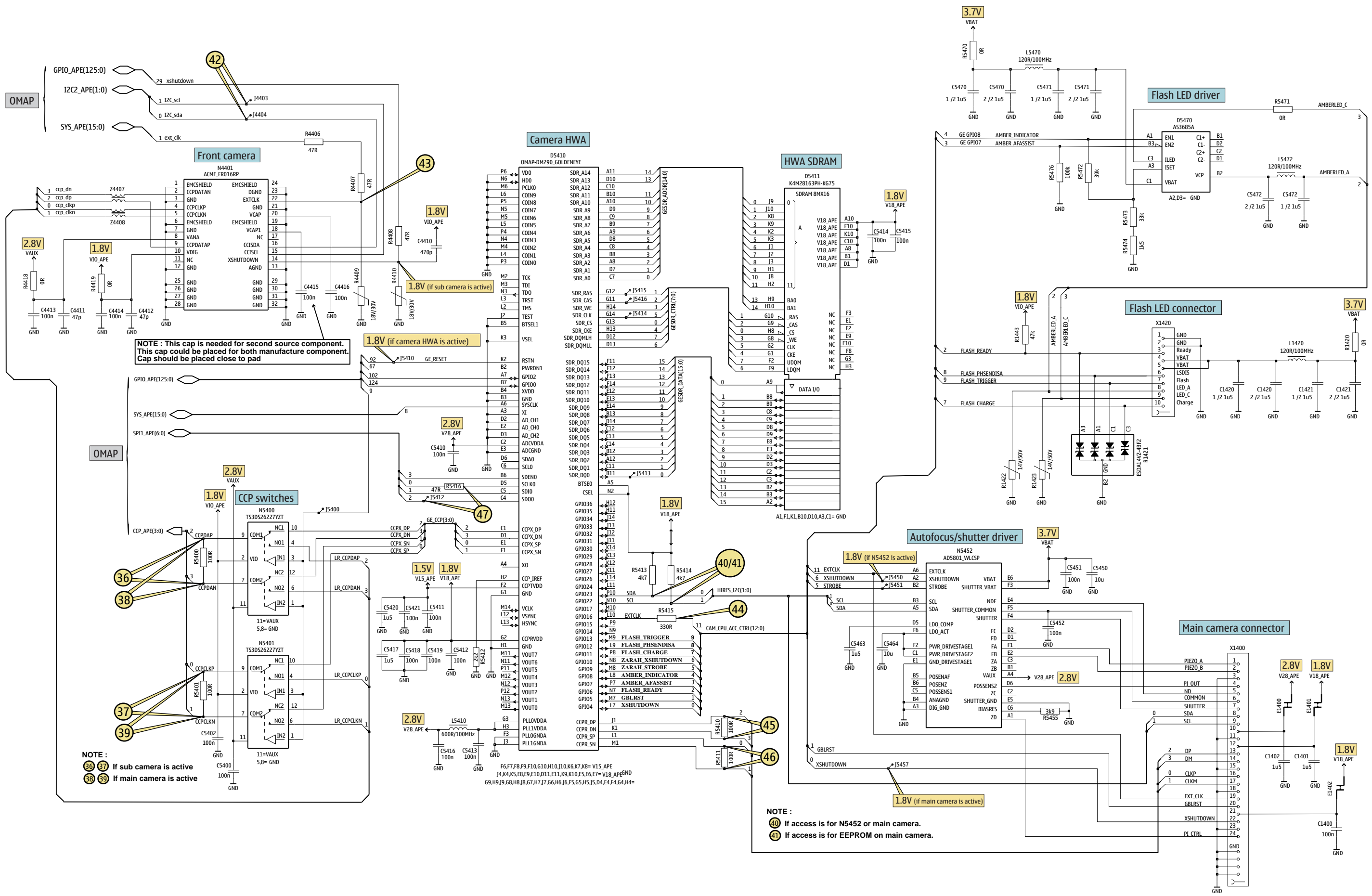

Please note:

All parts in this area are not assembled in RM-314!

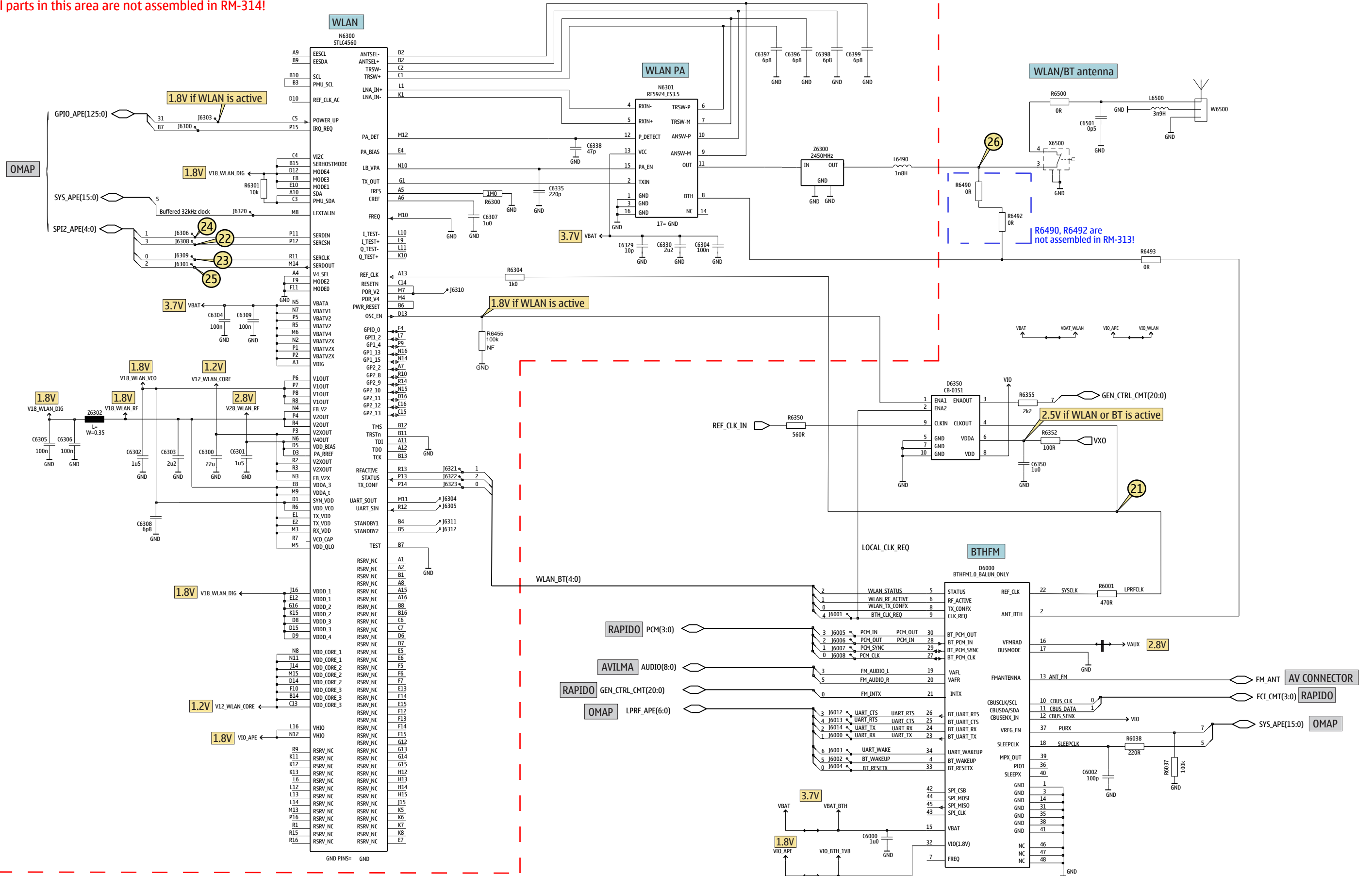

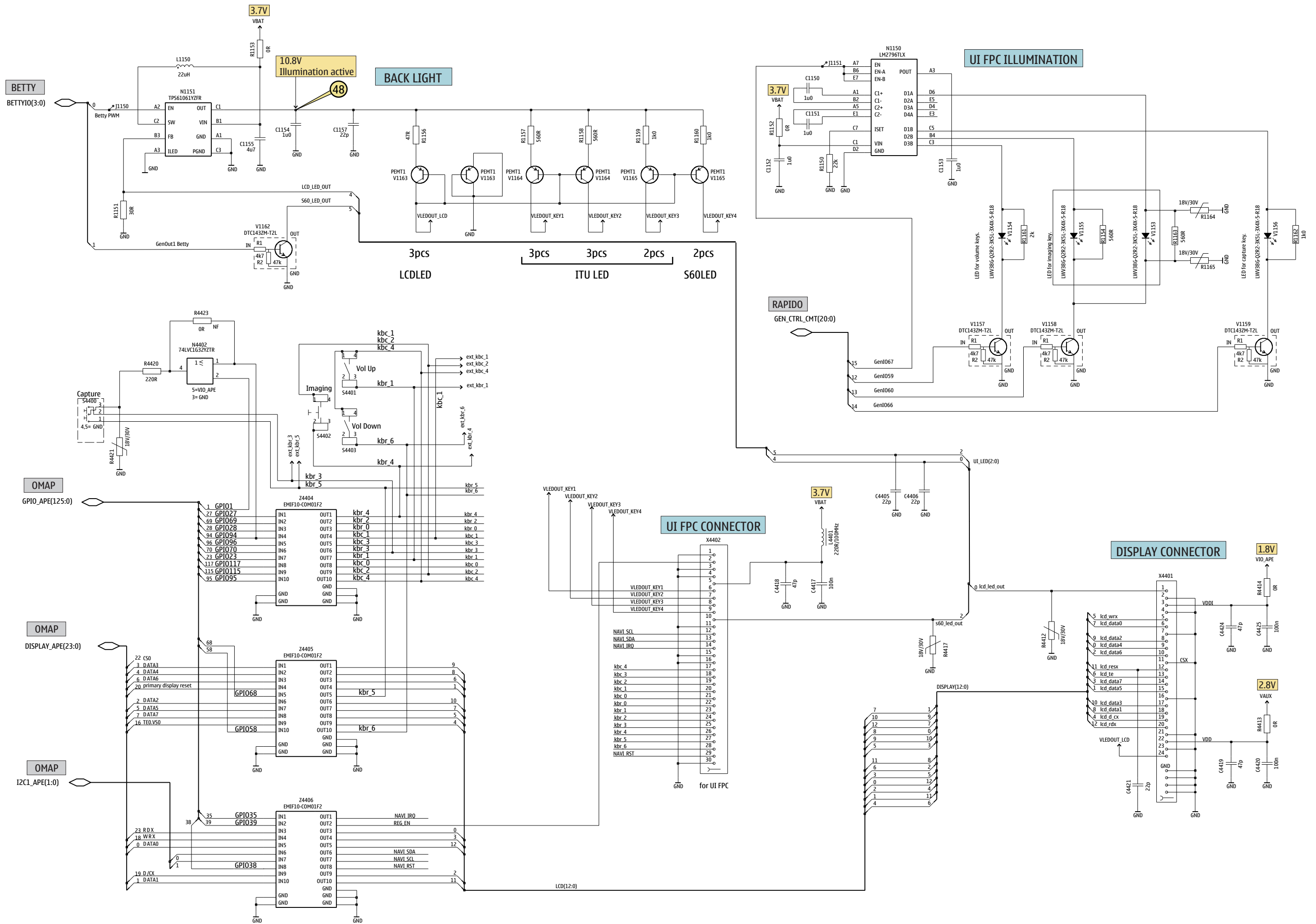

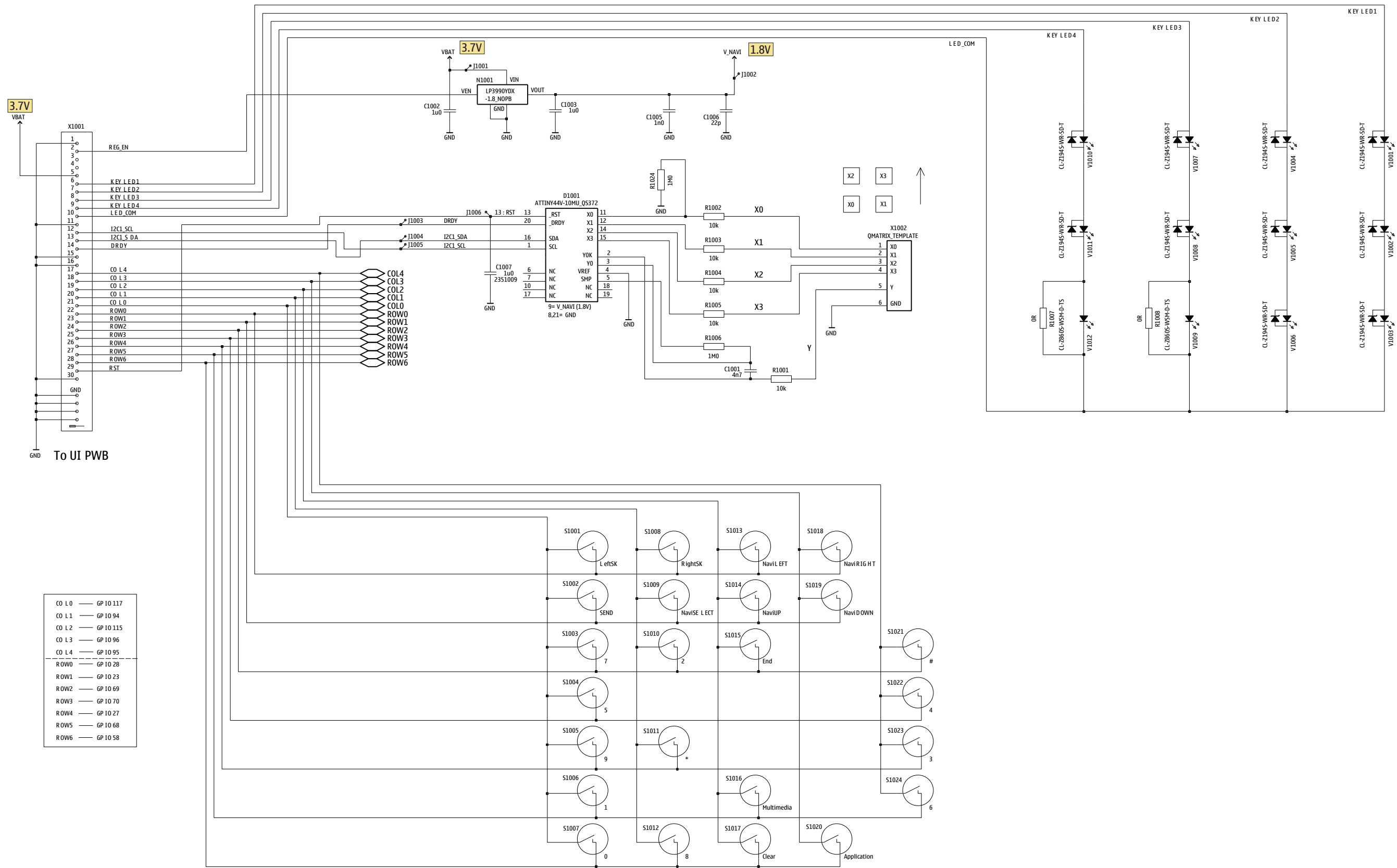

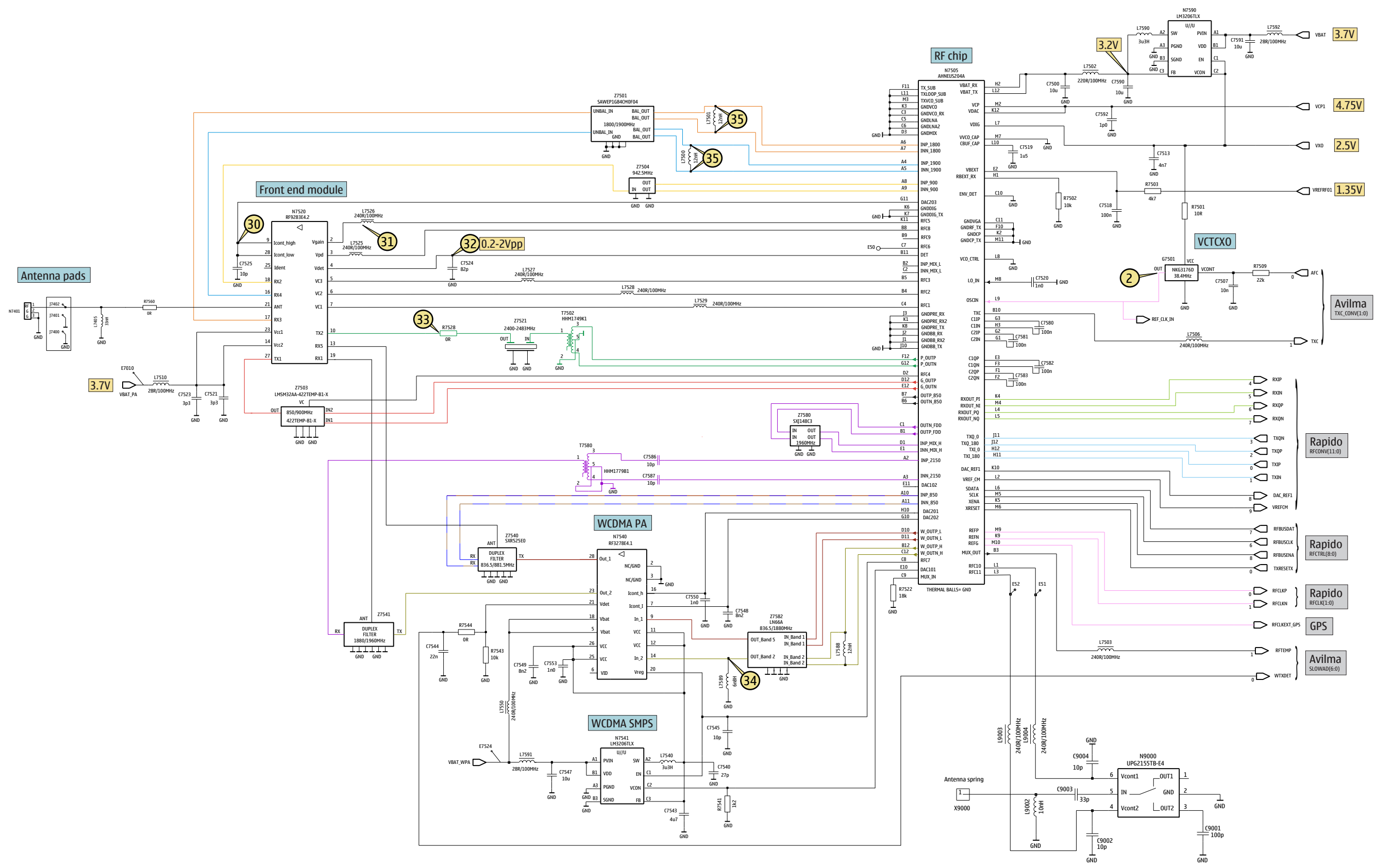

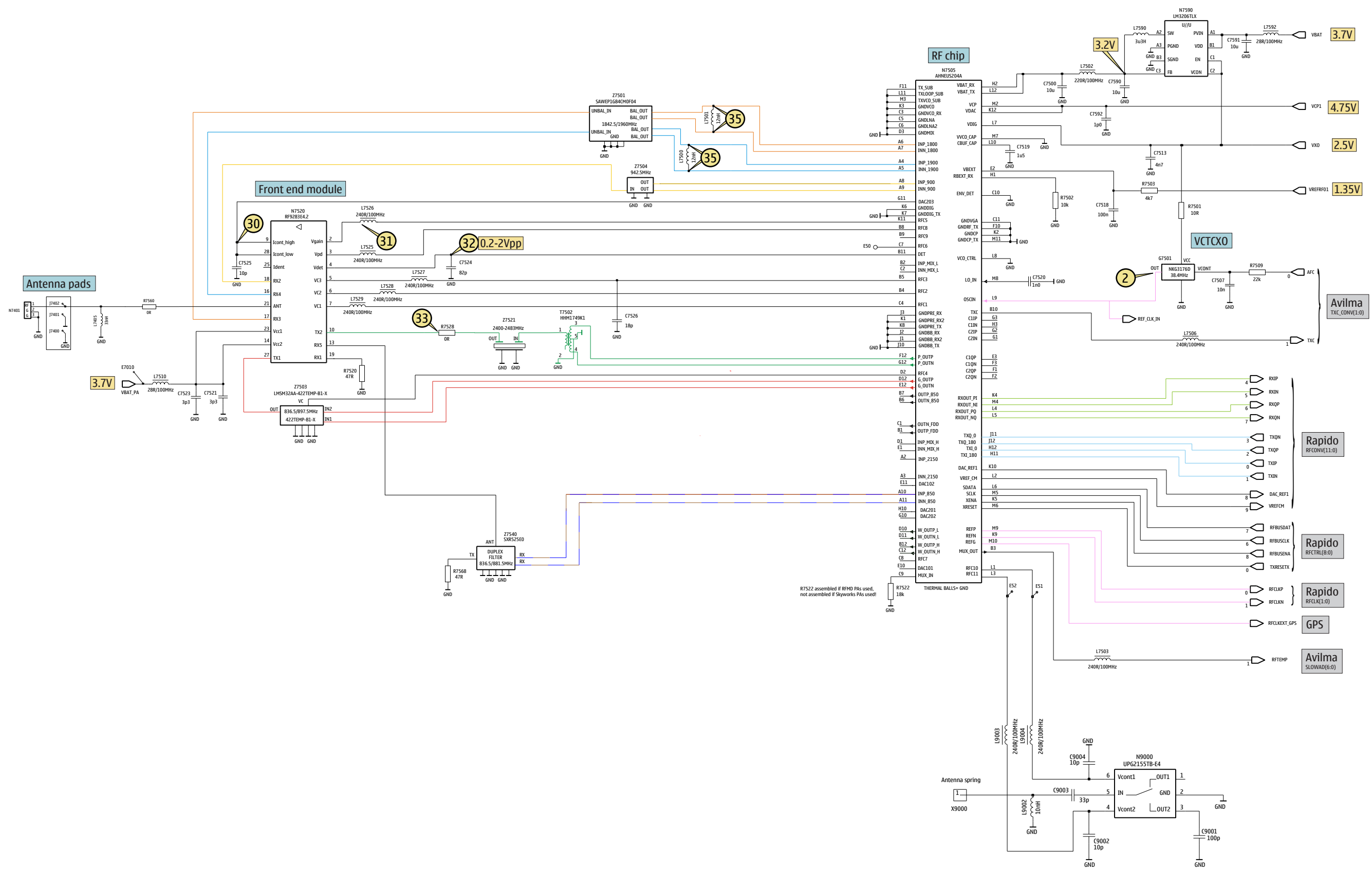

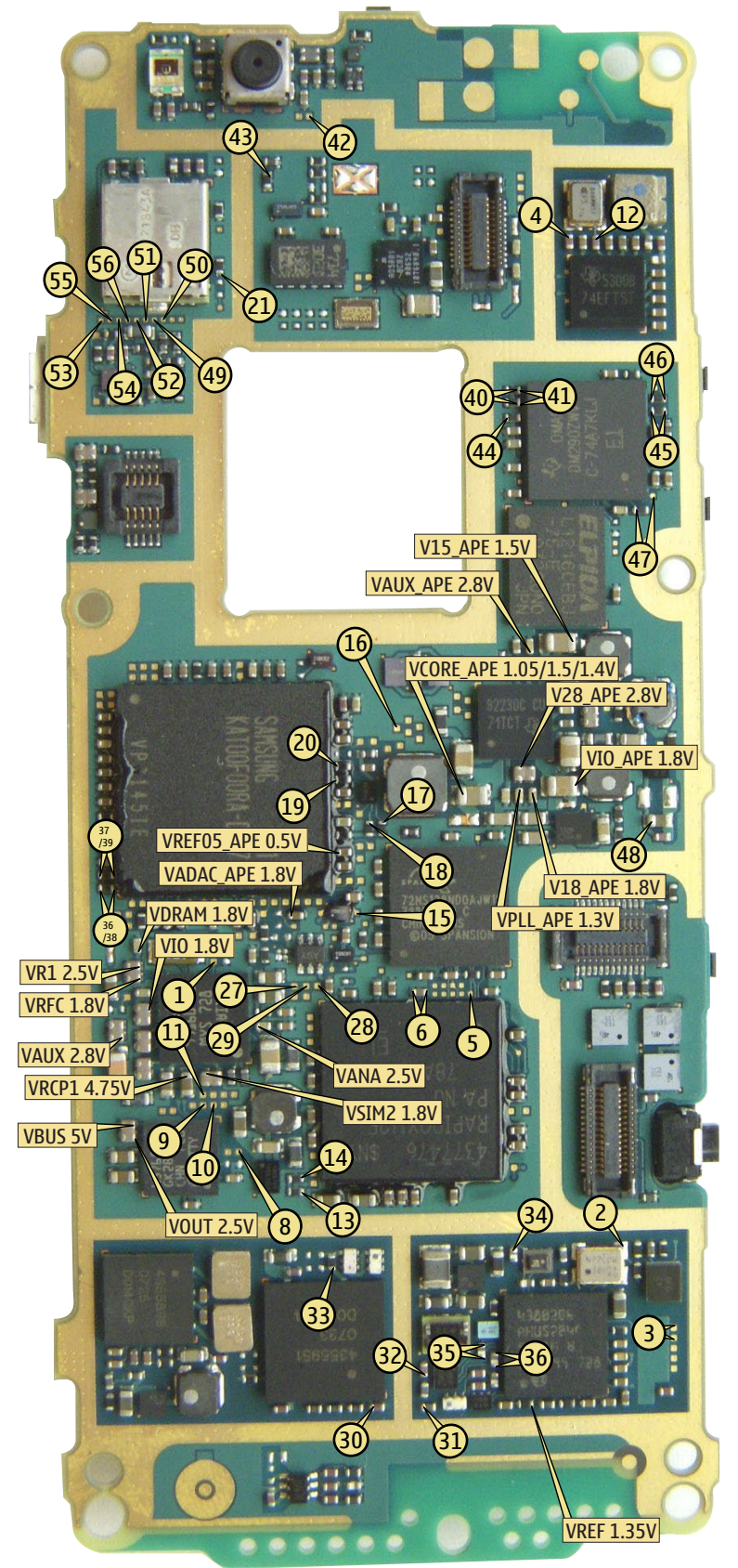
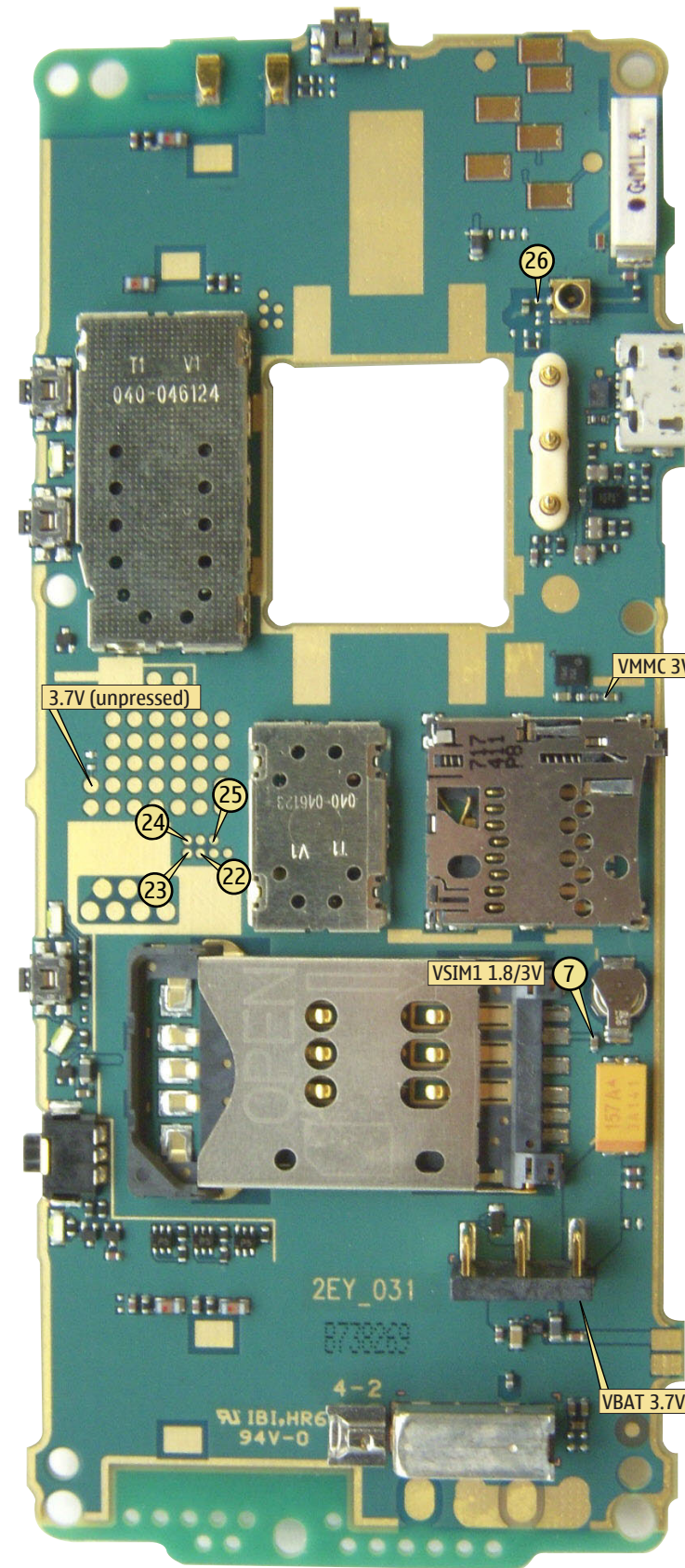
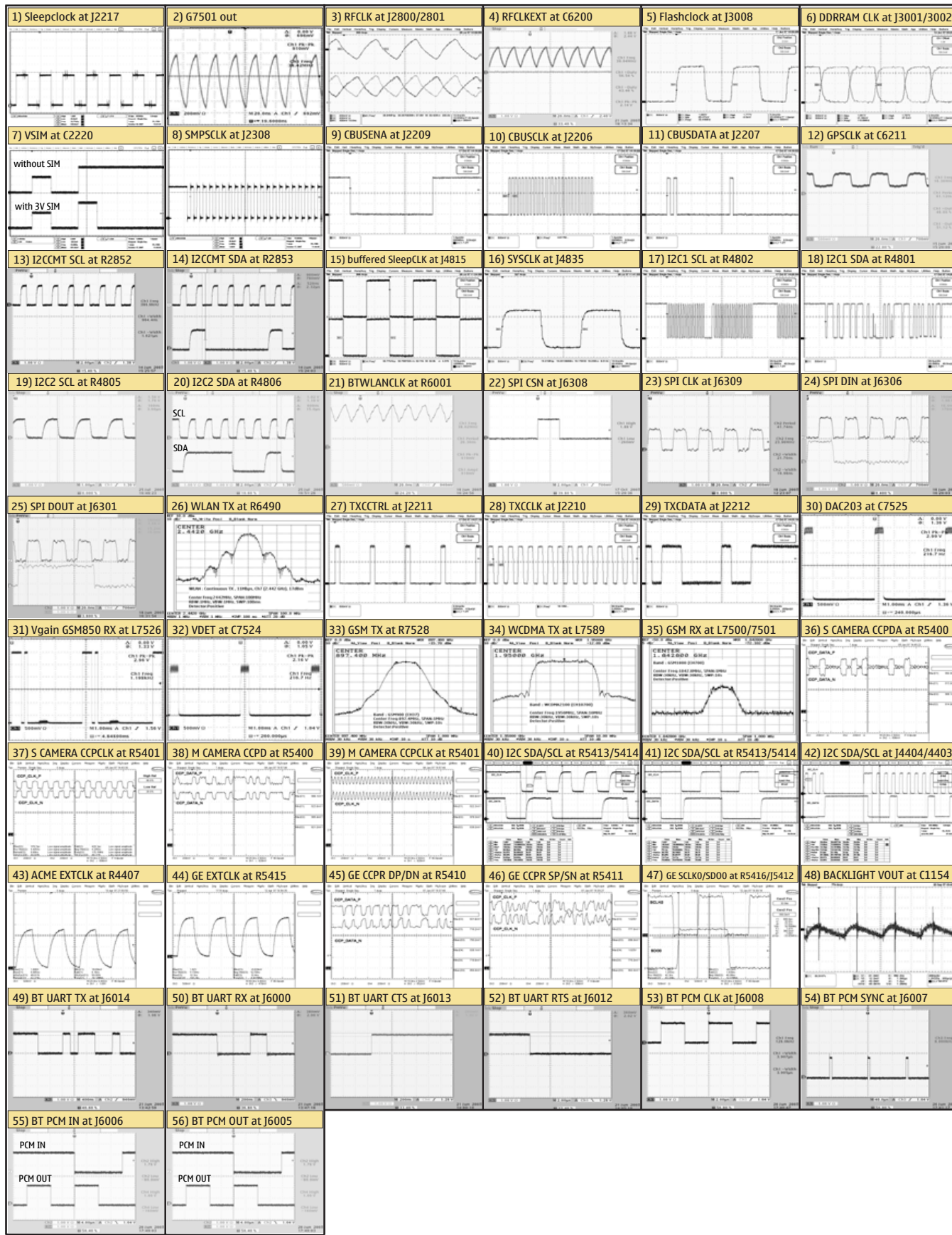

B	C2815	D7	C5463	E19	J1151	H11	J4827	F12	J6306	G11	N5650	D9	R5650	D9	
B2200	B9	C2816	F9	C5464	F18	J2030	C21	J4828	F12	J6308	G11	N6200	H18	R6001	C18
C	C2817	E9	C5470	B15	J2032	A17	J4829	F12	J6309	G11	N6300	H16	R6037	C19	
C1100	E19	C2818	E6	C5471	B16	J2033	A17	J4830	F12	J6310	G11	N6301	H17	R6038	B20
C1101	D19	C2819	E6	C5472	B15	J2034	B20	J4831	F12	J6311	F18	N7505	H4	R6300	G17
C1150	G11	C3000	F9	C5500	E10	J2060	H10	J4832	F12	J6312	F18	N7520	D4	R6301	G14
C1151	G11	C3001	G11	C5650	E9	J2100	F11	J4833	F12	J6313	G15	N7540	B4	R6304	G14
C1152	H11	C3002	F10	C6000	B20	J2200	D8	J4834	F12	J6321	F18	N7541	B3	R6350	I5
C1153	G11	C3003	F11	C6002	B20	J2201	C7	J4835	E12	J6322	F18	N7590	F5	R6352	I5
C1154	I11	C3004	E10	C6200	H19	J2202	C7	J4836	E11	J6323	F18	N9000	D2	R6355	I5
C1155	I12	C3005	G9	C6201	I19	J2203	D8	J4837	B13	J9052	I3	R	R6493	C17	
C1157	I11	C3006	E10	C6202	I19	J2204	C7	J4838	C10	J9053	I3	R1150	H11	R6500	A18
C1400	F19	C3007	E9	C6203	I18	J2205	C7	J4839	B13	J9054	I4	R1151	I12	R7501	H4
C1401	G18	C3008	F9	C6204	I19	J2206	C7	J4840	C10	L		R1152	H11	R7502	H3
C1402	G19	C4200	G13	C6205	H19	J2207	C7	J4842	B9	L1150	I12	R1153	H12	R7503	G3
C1420	A16	C4201	H12	C6206	I18	J2208	C9	J4843	B10	L1420	A15	R1154	I8	R7509	H5
C1421	A15	C4202	H13	C6207	H19	J2209	C7	J4844	B9	L2000	B4	R1156	F5	R7522	G4
C1440	C15	C4203	G11	C6209	I18	J2210	D9	J4845	B9	L2001	B17	R1157	G5	R7528	E5
C2000	C4	C4204	G13	C6210	I18	J2211	D9	J4846	E9	L2002	B17	R1158	G5	R7541	A3
C2001	C4	C4205	F11	C6211	H19	J2212	D9	J4847	E9	L2003	C20	R1159	H5	R7543	B4
C2002	B17	C4206	H13	C6212	I17	J2213	D8	J4848	B10	L2004	B17	R1160	H5	R7544	B4
C2003	B17	C4207	D10	C6300	I17	J2214	D8	J4849	B10	L2005	C17	R1161	I16	R7560	C3
C2004	B17	C4208	G11	C6301	I16	J2215	D8	J4850	C13	L2006	D19	R1162	I5	S	
C2005	C17	C4209	F12	C6302	I15	J2216	C9	J4851	G12	L2101	E11	R1163	I9	S4400	I6
C2008	C20	C4211	G13	C6303	I16	J2217	C9	J4852	G12	L2102	G4	R1164	I9	S4401	I17
C2009	C20	C4212	G11	C6304	H18	J2218	B9	J4853	E11	L2103	H4	R1165	I9	S4402	I9
C2013	D19	C4213	H12	C6305	H14	J2219	C7	J5100	H12	L2104	E11	R1420	A15	S4403	I15
C2014	B16	C4214	H12	C6306	G14	J2220	D6	J5101	H12	L2105	C7	R1421	A15	S4416	E22
C2015	B16	C4215	H12	C6307	G17	J2221	D6	J5102	H12	L2106	C7	R1422	A15	T	
C2018	B17	C4216	H11	C6308	G17	J2300	B7	J5103	H12	L2111	F11	R1423	A15	T7502	E5
C2030	F11	C4219	E10	C6309	I16	J2301	B7	J5104	G12	L2112	H20	R1440	B15	T7580	F3
C2031	E11	C4221	G11	C6329	H18	J2302	C6	J5105	I12	L2113	H18	R1443	B16	V	
C2032	F12	C4405	I5	C6330	I17	J2308	C6	J5106	H12	L2114	F11	R1444	C15	V1153	I10
C2033	F11	C4406	I9	C6335	I17	J2800	I4	J5107	I12	L2120	F10	R2000	C4	V1154	I16
C2034	F12	C4410	E21	C6338	H18	J2801	I4	J5108	G12	L2202	B7	R2002	B17	V1155	I8
C2035	F12	C4411	D21	C6350	I5	J2802	D6	J5109	H12	L2205	D8	R2004	B17	V1156	I5
C2036	E12	C4412	C21	C6396	G17	J2850	G7	J5113	H12	L2390	D7	R2005	C17	V1157	I13
C2037	F11	C4413	D21	C6397	G17	J3000	G8	J5114	G12	L2391	D6	R2006	A17	V1158	I8
C2071	B7	C4414	C21	C6398	G17	J3001	F8	J5127	G12	L3300	B16	R2007	B17	V1159	I5
C2072	A6	C4415	C21	C6399	H18	J3002	F9	J5200	G13	L4200	F12	R2008	C17	V1162	I5
C2073	A6	C4416	D21	C6501	A18	J3003	F8	J5201	F13	L4201	H12	R2009	D19	V1163	G5
C2106	G4	C4417	I7	C7500	H4	J3004	F8	J5202	G13	L4202	H13	R2010	D20	V1164	G5
C2107	H4	C4418	I7	C7507	G5	J3005	F9	J5203	G13	L4203	F11	R2012	D20	V1165	H5
C2108	B3	C4419	H10	C7513	H4	J3006	E9	J5204	G13	L4204	H13	R2071	F11	V4400	E21
C2109	B3	C4420	I10	C7518	G3	J3007	F9	J5205	G13	L4205	H11	R2106	G4	V4401	B21
C2110	B3	C4421	H9	C7519	H4	J3008	F8	J5206	F13	L4400	E21	R2107	H4	W	
C2116	H20	C4422	B20	C7520	H3	J3009	G11	J5207	D9	L4401	I8	R2116	H20	W6500	A20
C2117	G18	C4423	B20	C7521	D3	J3010	F9	J5390	E9	L4403	C21	R2117	G18	X	
C2118	E10	C4424	I9	C7523	D5	J3011	E9	J5391	E9	L4800	E12	R2120	F11	X1400	G19
C2119	F10	C4425	H9	C7524	F3	J3012	F8	J5400	F13	L5200	B13	R2121	F11	X1420	B15
C2120	F10	C4800	C13	C7525	E3	J3013	F9	J5410	I17	L5410	I16	R2200	D8	X1440	C16
C2122	F10	C4801	E12	C7540	C4	J3100	H12	J5412	I15	L5470	B15	R2300	G6	X2060	E18
C2123	F10	C4802	C13	C7543	C4	J3101	H11	J5413	H15	L5472	B15	R2852	D6	X2070	C5
C2124	F10	C4803	C10	C7544	B4	J3102	H11	J5414	G15	L6200	I19	R2853	D6	X3300	A17
C2125	F10	C4804	C10	C7545	B4	J3103	H11	J5415	H15	L6201	I18	R2862	E9	X4401	H9
C2126	E10	C4806	B11	C7547	B3	J3104	I11	J5416	H14	L6490	C18	R3000	F9	X4402	H7
C2127	E10	C4807	B11	C7548	B4	J3105	I11	J5450	E18	L6500	B19	R3300	B16	X5250	C11
C2128	F10	C4808	B13	C7549	C4	J3106	I12	J5451	E18	L7405	C3	R3301	B17	X5255	E8
C2129	F10	C4810	E12	C7550	B4	J3107	G11	J5452	G19	L7500	G4	R4400	D9	X6500	B18
C2201	B9	C4814	E11	C7553	C4	J3108	H11	J5453	G19	L7501	G4	R4403	F21	Z	
C2202	D9	C4816	B12	C7580	H3	J3109	H11	J5454	D20	L7502	G5	R4404	F21	Z4404	I7
C2203	D8	C4817	E12	C7581	H3	J3110	H12	J5455	G19	L7503	G3	R4406	D9	Z4405	H8
C2205	C9	C4818	B10	C7582	H3	J3111	G11	J5456	H18	L7506	H5	R4407	D19	Z4406	I8
C2211	B8	C4819	B11	C7583	H3	J3112	G11	J5457	F19	L7510	D5	R4408	E21	Z4407	D21
C2213	B9	C4820	B11	C7586	F3	J3113	G11	J5458	F19	L7525	F3	R4409	D20	Z4408	C21
C2215	B8	C4821	B12	C7587	F3	J3114	H11	J5500	C10	L7526	F3	R4410	E21	Z5200	B13
C2216	B9	C4822	E11	C7590	F5	J3300	B17	J5501	D10	L7527	E3	R4412	I9	Z6200	I19
C2217	D8	C4823	C10	C7591	F4	J3301	B16	J5502	D10	L7528	E3	R4413	I10	Z6300	G17
C2220	C7	C4824	C13	C7592	I3	J4400	I11	J5503	C9	L7529	D3	R4414	H9	Z7501	F3
C2222	C7	C4825	B12	C9001	D2	J4401	I11	J5504	D10	L7540	C3	R4417	I6	Z7503	F4
C2225	B7	C4826	D13	C9002	D2	J4403	D20	J5505	D10	L7550	A3	R4418	C20	Z7504	G4
C2226	B9	C4827	C10	C9003	D2	J4404	D20	J5506	D10	L7580	G3	R4419	B21	Z7521	E5
C2227	B8	C4828	E12	C9004	D2	J4800	E12	J5507	D10	L7588	G5	R4420	I6	Z7540	C5
C2228	B8	C4830	B12	D	J4801	E10	J5508	D10	L7589	G5	R4421	I6	Z7541	C4	
C2231	D8	C4832	B11	D2800	F7	J4802	E10	J6000	B18	L7590	F5	R4800	C13	Z7580	G3
C2232	B8	C4833	E10	D3000	F10	J4803	E10	J6001	C19	L7591	B3	R4801	E11	Z7582	G5
C2250	D8	C4834	D13	D4800	C11	J4804	C13	J6002	B18	L7592	F4	R4802	E11		
C2251	D8	C4835	E12	D5000	C11	J4805	E10	J6002	B18	L9002	E2	R4804	E11		
C2300	C6	C4836	D13	D5390	E9	J4806	E10	J6003	C18	L9003	E2	R4805	E11		
C2303	B6	C5200	B13	D5410	H16	J4806	E10	J6004	C18	L9004	E2	R4806	E12		
C2304	C6	C5201	B13	D5411	H14	J4807	E10	J6005	B18	M		R5001	B10		
C2307	B6	C5255	B8	D5470	B15	J4808	A13	J6006	B18	M2100	D3	R5002	B11		
C2312	B7	C5390	E9	D5500	E10	J4809	B12	J6008	B18	N		R5003	B10		
C2390	D6	C5400	F13	D6000	B19	J4810	A12	J6012	B18	N1100	D18	R5004	B10		
C2391	C7	C5402	F13	D6350	I5	J4811	B13	J6013	B18	N1150	H11	R5400	B10		
C2800	E9	C5410	I15	E	J4812	E12	J6014	B18	N1151	I11	R5401	B10			
C2801	G7	C5411	I16	E2001	C21	J4813	C9	J6200	G6	N2000	F12	R5410	I16		
C2802	G7	C5412	I16	E2002	C20	J4814	D9	J6201	G7	N2001	B17	R5411	I16		
C2803	G8	C5413	I16	E2003	C21	J4815	E10	J6202	H18	N2120	F11	R5412	I17		
C2804	D7	C5414	G15	E2004	C19	J4816	E12	J6203	H18	N2200	C8	R5413	G17		
C2805	E9	C5415	H14	E2005	C20	J4817	E12	J6204	H18	N2300	C6	R5414	G16		
C2806	D6	C5416	I15	E2006	C21	J4818	B13	J6210	H21	N2390	D6	R5415	G16		
C2807	D8	C5417	I15	F	J4819	B13	J6211	H21	N4200	G12	R5416	I15			
C2808	E6	C5418	H17	F2000	B4	J4820	B13	J6212	I5	N4400	D19	R5455	E19		
C2809	F6	C5419	G16	G	J4821	D10	J6213	E9	N4401	D21	R5470	B15			
C2810	G6	C5420	G16	G2200	B9	J4822	B13	J6300	G11	N4402	D13	R5471	B15		
C2811	G7	C5421	G16	G6200	H19	J4823	C10	J6301	G11	N4801	E11	R5472	A15		
C2812	F6	C5450</													

B	C2814	G9	C5464	F18	J2802	D6	J5114	G12	L5472	B15	R4417	I6	
B2200	B9	C2815	D7	C5470	B15	J2850	G7	J5127	G12	L6200	I19	R4418	C20
C	C2816	F9	C5471	B16	J3000	G8	J5200	G13	L6201	I18	R4419	B21	
C1100	E19	C2817	E9	C5472	B15	J3001	F8	J5201	F13	L6500	B19	R4420	I6
C1101	D19	C2818	E6	C5500	E10	J3002	F9	J5202	G13	L7405	C3	R4421	I6
C1150	G11	C3000	F9	C5650	E9	J3003	F8	J5203	G13	L7500	G4	R4800	C13
C1151	G11	C3001	G11	C6000	B20	J3004	F8	J5204	G13	L7501	G4	R4801	E11
C1152	H11	C3002	E10	C6002	B20	J3005	F9	J5205	G13	L7502	G5	R4802	E11
C1153	G11	C3003	F11	C6200	H19	J3006	E9	J5206	F13	L7503	G3	R4804	E11
C1155	I12	C3004	E10	C6201	H19	J3007	F9	J5207	D9	L7506	H5	R4805	E11
C1156	I11	C3005	G9	C6202	I19	J3008	F8	J5390	E9	L7510	D5	R4806	E12
C1157	I11	C3006	E10	C6203	I18	J3009	G11	J5391	E9	L7525	F3	R5001	B10
C1400	F19	C3007	E9	C6204	I19	J3010	F9	J5400	F13	L7526	F3	R5002	B11
C1401	G18	C3008	F9	C6205	H19	J3011	E9	J5410	I17	L7527	E3	R5003	B10
C1402	G19	C4200	G13	C6206	I18	J3012	F8	J5412	I15	L7528	E3	R5004	B10
C1420	A16	C4201	H12	C6207	H19	J3013	F9	J5413	H15	L7529	D3	R5400	B10
C1421	A15	C4202	H13	C6209	I18	J3100	H12	J5414	G15	L7590	F5	R5401	B10
C1440	C15	C4203	G11	C6210	I18	J3101	H11	J5415	H15	L7592	F4	R5410	I16
C2000	C4	C4204	G13	C6211	H19	J3102	H11	J5416	H14	L9002	E2	R5411	I16
C2001	C4	C4205	F11	C6212	I17	J3103	H11	J5450	E18	L9003	E2	R5412	I17
C2002	B17	C4206	H13	C6350	I5	J3104	I11	J5451	E18	L9004	E2	R5413	G17
C2003	B17	C4207	D10	C6501	A18	J3105	I11	J5452	G19	M		R5414	G16
C2004	B17	C4208	G11	C7500	H4	J3106	I12	J5453	G19	M2100	D3	R5415	G16
C2005	C17	C4209	F12	C7507	G5	J3107	G11	J5454	G20	N		R5416	I15
C2008	C20	C4211	G13	C7513	H4	J3108	H11	J5455	G19	N1100	D18	R5455	E19
C2009	C20	C4212	G11	C7518	H3	J3109	H11	J5456	E18	N1150	H11	R5470	B15
C2013	D19	C4213	H12	C7519	H4	J3110	H12	J5457	F19	N1151	I11	R5471	B15
C2014	B16	C4214	H12	C7520	H3	J3111	G11	J5458	F19	N2000	F12	R5472	A15
C2015	B16	C4215	H12	C7521	D3	J3112	G11	J5500	C10	N2001	B17	R5473	A15
C2018	B17	C4216	H11	C7523	D5	J3113	G11	J5501	D10	N2120	F11	R5474	A16
C2030	F11	C4219	E10	C7524	F3	J3114	H11	J5502	D10	N2200	C8	R5476	B16
C2031	E11	C4221	G11	C7525	E3	J3300	B17	J5503	C9	N2300	C6	R5650	D9
C2032	F12	C4405	I5	C7590	F5	J3301	B16	J5504	D10	N2390	D6	R6000	C18
C2033	F11	C4406	I9	C7591	F4	J4400	I11	J5505	D10	N4200	G12	R6001	C18
C2034	F12	C4410	E21	C7592	I3	J4401	I11	J5506	D10	N4400	D19	R6037	C19
C2035	F12	C4411	D21	C9001	D2	J4403	D20	J5507	D10	N4401	D21	R6038	B20
C2036	E12	C4412	C21	C9002	D2	J4404	D20	J5508	D10	N4402	D13	R6350	I5
C2037	F11	C4413	D21	C9003	D2	J4800	E12	J6000	B18	N4801	E11	R6352	I5
C2071	B7	C4414	C21	C9004	D2	J4801	E10	J6001	C19	N5400	F13	R6355	I5
C2072	A6	C4415	C21	D	J4802	E10	J6002	B18	N5401	E13	R6493	C18	
C2073	A6	C4416	D21	D2800	F7	J4803	F10	J6003	C18	N5452	F18	R6500	A18
C2102	B3	C4417	I7	D3000	F10	J4804	C13	J6004	C18	N5650	D9	R7501	H4
C2103	B3	C4418	I7	D4800	C11	J4805	E10	J6005	B18	N6200	H18	R7502	H3
C2106	G4	C4419	H10	D5000	C11	J4806	E10	J6006	B18	N7505	H4	R7503	G3
C2107	H4	C4420	I10	D5390	E9	J4807	E10	J6007	B18	N7520	D4	R7509	H5
C2108	B3	C4421	H9	D5410	H16	J4808	A13	J6008	B18	N7590	F5	R7522	G4
C2109	B3	C4422	B20	D5411	H14	J4809	B12	J6012	B18	N9000	D2	R7528	E5
C2110	B3	C4423	B20	D5470	B15	J4810	A12	J6013	B18	R		R7560	C3
C2116	H20	C4424	I9	D5500	E10	J4811	B13	J6014	B18	R1150	H11	R7568	C5
C2117	G18	C4425	H9	D6000	B19	J4812	E12	J6200	G6	R1151	I12	R7569	C4
C2118	E10	C4800	C13	D6350	I5	J4813	C9	J6201	G7	R1152	H11	S	
C2119	F10	C4801	E12	E	J4814	D9	J6202	H18	R1153	H12	S4400	I6	
C2120	F10	C4802	C13	E2001	C21	J4815	E10	J6203	H18	R1156	F5	S4401	I17
C2122	F10	C4803	C10	E2002	C20	J4816	E12	J6204	H18	R1157	G5	S4402	I9
C2123	F10	C4804	C10	E2003	C21	J4817	E12	J6210	H21	R1158	G5	S4403	I15
C2124	F10	C4806	B11	E2004	C19	J4818	B13	J6211	H21	R1159	H5	S4416	E22
C2125	F10	C4807	B11	E2005	C20	J4819	B13	J6212	E22	R1160	H5	T	
C2126	E10	C4808	B13	E2006	C21	J4820	B13	J6213	H19	R1164	I9	T7502	E5
C2127	E10	C4810	E12	F	J4821	D10	J9052	I3	R1165	I9	V		
C2128	F10	C4814	E11	F2000	B4	J4822	B13	J9053	I3	R1420	A15	V1153	I10
C2129	F10	C4816	B12	G	J4823	C10	J9054	I4	R1421	A15	V1154	I16	
C2201	B9	C4817	E12	G2200	B9	J4824	B10	L	R1422	A15	V1155	I8	
C2202	D9	C4818	B10	G6200	H19	J4825	H12	L1150	I12	R1423	A15	V1156	I5
C2203	D8	C4819	B11	G7501	H5	J4826	E11	L1420	A15	R1440	B15	V1157	I13
C2205	C9	C4820	B11	J	J4827	F12	L1440	C15	R1443	B16	V1158	I8	
C2211	B8	C4821	B12	J1150	I12	J4828	F12	L2000	B4	R2000	C4	V1159	I5
C2213	B9	C4822	E11	J1151	H11	J4829	F12	L2001	B17	R2002	B17	V1162	I5
C2215	B8	C4823	C10	J2030	C21	J4830	B17	L2002	B17	R2004	B17	V1163	G5
C2216	B9	C4824	C13	J2032	A16	J4831	F12	L2003	C20	R2005	C17	V1164	G5
C2217	D8	C4825	B12	J2033	A17	J4832	F12	L2004	B17	R2006	A17	V1165	H5
C2220	C7	C4826	D13	J2034	B20	J4833	F12	L2005	C17	R2007	B17	V4400	E21
C2222	C7	C4827	C10	J2060	H10	J4834	F12	L2006	D19	R2008	C17	V4401	B21
C2225	B7	C4828	E12	J2100	F11	J4835	E12	L2101	E11	R2009	D19	W	
C2226	B9	C4830	B12	J2200	D8	J4836	E11	L2102	G4	R2010	D20	W6500	A20
C2227	B8	C4832	B11	J2201	C7	J4837	B13	L2103	H4	R2012	D20	X	
C2228	B8	C4833	E10	J2202	C7	J4838	C10	L2104	E11	R2071	F11	X1400	G19
C2231	D8	C4834	D13	J2203	D8	J4839	B13	L2105	C7	R2106	G4	X1420	B15
C2232	B8	C4835	E12	J2204	C7	J4840	C10	L2106	C7	R2107	H4	X1440	C16
C2250	D8	C4836	D13	J2205	C7	J4842	B9	L2111	F11	R2116	H20	X2060	F18
C2251	D8	C5200	B13	J2206	C7	J4843	B10	L2112	H20	R2117	G18	X2070	C5
C2300	C6	C5201	B13	J2207	C7	J4844	B9	L2113	H18	R2120	F11	X3300	A17
C2303	B6	C5255	B8	J2208	C9	J4845	B9	L2114	F11	R2121	F11	X4401	H9
C2304	C6	C5390	E9	J2209	C7	J4846	E9	L2120	F10	R2200	D8	X4402	H7
C2307	B6	C5400	F13	J2210	D9	J4847	E9	L2202	B7	R2300	C6	X5250	C11
C2312	B7	C5402	F13	J2211	D9	J4848	B10	L2205	D8	R2852	D6	X5255	E8
C2390	D6	C5410	I15	J2212	D9	J4849	B10	L2390	D7	R2853	D6	X6500	B18
C2391	C7	C5411	I16	J2213	D8	J4850	C13	L2391	D6	R2862	E9	Z	
C2800	E9	C5412	I16	J2214	D8	J4851	G12	L3300	B16	R3000	F9	Z4404	I7
C2801	G7	C5413	I16	J2215	D8	J4852	G12	L4200	F12	R3300	B16	Z4405	H8
C2802	G8	C5414	G15	J2216	C9	J4853	E11	L4201	H12	R3301	B17	Z4406	I8
C2803	G7	C5415	H14	J2217	C9	J5100	H12	L4202	H13	R4400	D9	Z4407	D21
C2804	D7	C5416	I15	J2218	B8	J5101	H12	L4203	F11	R4403	F21	Z4408	C21
C2805	E9	C5417	I15	J2219	C7	J5102	H12	L4204	H13	R4404	F21	Z5200	B13
C2806	D8	C5418	H17	J2220	D6	J5103	H12	L4205	H11	R4406	D9	Z6200	I19
C2807	D6	C5419	G16	J2221	D6	J5104	G12	L4400	E21	R4407	D19	Z7501	F3
C2808	E6	C5420	G16	J2300	B7	J5105	I12	L4401	I8	R4408	E21	Z7503	F4
C2809	F6	C5421	G16	J2301	B7	J5106	H12	L4403	C21	R4409	D20	Z7504	G4
C2810	G6	C5450	F18	J2302	C6	J5107	I12	L4800	E12	R4410	E21	Z7521	E5
C2811	G7	C5451	F19	J2308	C6	J5108	G12	L5200	B13	R4412	I9	Z7540	C5
C2812	F6	C5452	F19	J2800	I4	J5109	H12	L5410	I16	R4413	I10		
C2813	D7	C5463	E19	J2801	I4	J5113	H12	L5470	B15	R4414	H9		

